

RESEARCH ARTICLE

Design of fertilizer seeder for *Houttuynia cordata*Qin Zou¹, Chuanmei Hu^{1,*}, Aoting Zhang¹, Linlan Shao¹, Zhihong Li¹, Quanwen Rao²¹Mechanical and Electrical School, Chengdu University of Technology, Chengdu 610059, Sichuan, China.²Hongfucheng Precision Electronics (Chengdu) Co., Ltd, Chengdu 610097, Sichuan, China

Received: April 26, 2023; accepted: May 26, 2023.

Houttuynia coriacea is a perennial herb with a fishy smell. It can be used for both medicinal and edible purposes and has high use value. Because of its cumbersome planting process, most places are still mainly cultivated artificially. In order to address the issue of high input costs and low yields associated with the current predominantly manual planting methods for *Houttuynia cordata*, a fertilizer seeder for *Houttuynia Cordata* (FSHC) was developed by this study. A seeding device capable of multi-level scattering had been specially designed to greatly improve planting efficiency compared to manual planting, which not only increased the yield of *Houttuynia cordata* and farmers' income, but also improved land utilization. From the perspective of sowing agronomy, the positions of the functional blocks of the sowing machine and the relevant design parameters were reasonably arranged. Through innovative design of the seeding device, the scattering of *Houttuynia cordata* could be achieved, meeting the requirements of sowing. Compared with the current planting methods, the resulted fertilizer seeder from this study could not only improve efficiency and reduce the costs, but also promote the development of agricultural mechanization to a certain extent.

Keywords: *Houttuynia cordata*; sowing; metering device.

*Corresponding author: Chuanmei Hu, Mechanical and Electrical School, Chengdu University of Technology, Chengdu 610059, Sichuan, China. Email: huchuanmei59@gmail.com.

Introduction

With the rapid development of agricultural technology, the level of agricultural mechanization is becoming more demanding [1]. At present, the crops with relatively regular seed shapes have been mechanized sowing and harvesting already [2]. Alternatively, the irregularly shaped rhizome crops are less mechanized [3]. So, there is plenty of room for mechanization to grow. Typical root crops such as *Houttuynia cordata* are mainly planted in the central, southeast, and southwest of China [4, 5]. Because of the irregular shape of the roots and stems and the flexible long cylindrical shape, it is difficult to realize mechanization sowing. In

addition, the sowing process is complicated, so the soil needs to be loosened, ditched, and fertilized before sowing. Then, the *Houttuynia cordata* will be placed section by section in the direction parallel to the seeding ditch [6], and finally the planting will be completed through soil cover [7]. Therefore, the mechanization sowing system of *Houttuynia cordata* has not been improved.

Houttuynia cordata can be used as food materials and medicinal materials [8] because it is rich in vitamin C, protein, and other nutritional components as well as volatile oil, flavonoids, and other active ingredients [9]. Its audience is wide, and the market demand is growing in

China. As the number of wild *Houttuynia cordata* decreases, the phenomenon of demand exceeds supply [10], which makes the market development trend getting better and better. As *Houttuynia cordata* has the characteristics of high utilization values, easy planting, low input, and high output values [11], the artificial planting area has been increasing. At present, most planting methods of *Houttuynia cordata* adopt artificial planting, which not only requires a lot of manpower and financial resources, but also uneven planting quality and low efficiency, which is difficult to ensure the quality of sowing.

In view of the long strip rhizome crops, the existing mechanization planting technology is not yet mature [12]. The research for *Houttuynia cordata* seeding machinery is relatively limited. Current production mechanization planting technology is mostly in stages type, rotary tillage, applying fertilizer, sow, cover earth apart [13]. Although compared with artificial cultivation, it has improved the efficiency of a certain, it still has the problem of high cost. On the other hand, although current *Houttuynia cordata* planter in the market achieved one-piece sowing, the metering device can cause a certain degree of damage to the seeds and cannot guarantee the sowing quality completely. For the purpose of solving the existing problems of *Houttuynia cordata* planting, this study developed a fertilizer seeder for *Houttuynia Cordata* (FSHC) and a seed seeder which could realize multistage evacuation.

Materials and Methods

Function of fertilizer seeder for *Houttuynia cordata* (FSHC)

In product development and design, black-box method is generally used to study its functions and characteristics [14], and then, reasonable modules are constructed, and corresponding structures are designed. In the black box method, according to the system after the qualitative description of the basic functions of thinking, the design is simpler. It can also facilitate inspired

designers to conceive update products, obtain better way of system function and designing principle [15]. The design of the black box for FSHC technology was shown in Figure 1. The entire system consisted with a pile of *Houttuynia cordata* and a pile of fertilizer as a black box input, considering the soil, the influence of humidity, depth of fertilize, and depth of planting. After a series of conversions in the system, noise and exhaust gas were generated along with the conversion of energy. The system ended in *Houttuynia cordata* distributed sowing and fertilizer sowing.

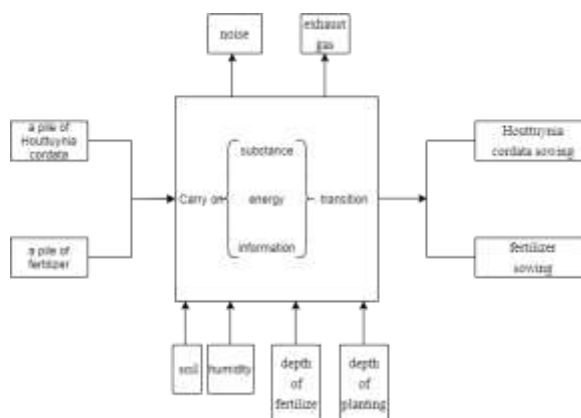

Figure 1. Black box of FSHC system.

The function decomposition

In the process of new product development, product functions are often classified according to technical conditions and process characteristics to form multi-level work units, and the interrelationships and functions between functional units at all levels are displayed in a function tree [16]. The total functions of FSHC were decomposed into the first level functions including power source, transmission, actuator, and control mechanism, and then, further decomposed to form the second level functions until they could not be decomposed anymore. A structure or method of implementing a function that cannot be further decomposed is called a function element. The functional tree formed by the functional decomposition of the *Houttuynia cordata* seeding fertilizer applicator was shown

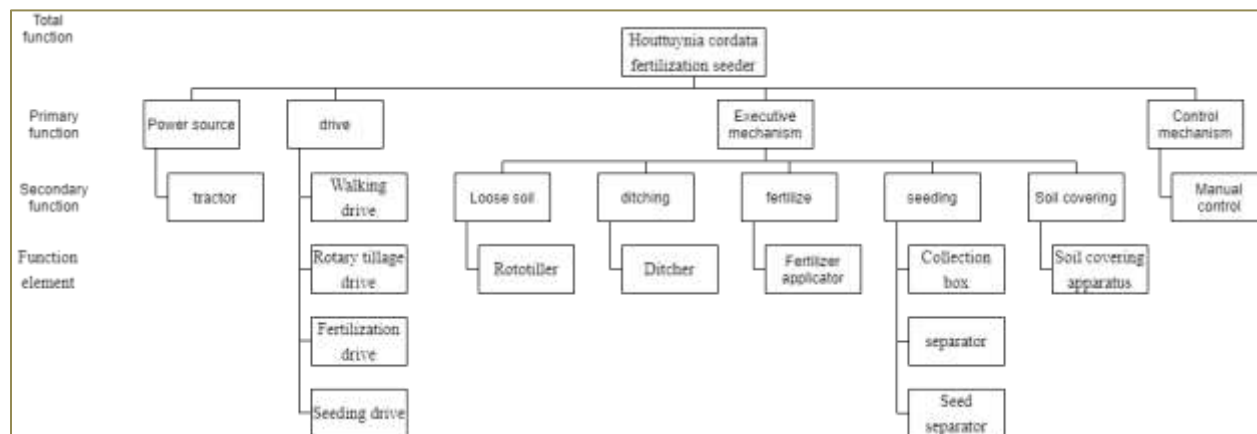

Figure 2. Function tree of fertilizer seeder for *Houttuynia cordata*.

Table 1. Transmission morphology matrix.

No.	Subfunction	Function element 1	Function element 2	Function element 3
A	tractor	Rear wheel drive (wheel)	Four-wheel drive (wheeled)	Caterpillar type
B	Walking drive	Gear drive	Chain drive	Belt drive
C	Rotary tillage drive	Cross shaft universal joint		
D	Fertilization drive	Gear drive	Chain drive	Belt drive
E	Seeding drive	Gear drive	Chain drive	Belt drive

Table 2. Actuators morphological matrix.

Subfunction	Function element 1	Function element 2	Function element 3	Function element 4
A Rototiller	Intermediate drive	Side drive		
B Ditcher	Hoe and shovel	Wing shovel	Double disc	Core share
C Fertilizer applicator	Outer groove wheel	Horizontal star wheel	Vertical star wheel	Vibrating
D Collection box	Square	Ladder	Semicircle	Single-side circular trapezoid
E Separator	Roller	Grid	Slide	Jitter
F Seed separator	Slotted wheel	Chain type spoon	Tian wheel	Conveyor belt
G Soil covering apparatus	Scraper	Shovel	Towing ring	Rotary wheel claw
H Suppression wheel	Cylindrical suppression wheel	Concave suppression wheel	Cone combination suppression wheel	Rubber suppression wheel

in Figure 2.

Principle design and verification for functional element

The functional element of FSHC was designed and verified by morphological matrix method, which was a comprehensive functional solution of systematic search and process-based calculation including the transmission morphology matrix calculation and actuator

morphological matrix calculation [17]. Table 1 listed the machine transmission parts for main transmission morphology matrix of FSHC. The design of the product in use was the primary guarantee of functional stability. The whole machine transmission scheme from the perspective of novelty and practicability generally selected A1, A2, B3, C1, D2, E2, and the number of schemes was $2 \times 1 \times 1 \times 1 \times 1 = 2$ (kinds).

Table 3. Function element solution carrier.

Subfunction	Functional carrier	Advantages
Tractor	Rear wheel drive (wheel)	Choose wheeled tractor rear wheel drive, suitable for drill into the groundwork, more suitable type used in hilly area of work, low cost
Walking drive	Belt drive	The whole machine walking tractor traction, through the diesel engine and walking wheel belt drive, more efficient, stable work
Rotary tillage drive	Cross shaft universal joint	The transmission is stable and reliable, and the angular compensation is large. The general variation range is 5°~45°
Fertilization drive	Chain drive	Suitable for low power transmission, large center distance, low cost, simple installation
Seeding drive	Chain drive	Suitable for low power transmission, large center distance, low cost, simple installation
Rototiller	Intermediate gear drive	Adopt intermediate transmission, the force on both sides of the cutter shaft is uniform when cutting soil, the transmission is stable, and can transfer larger power
Ditcher	Double disc furrow opener	When ditching can cut dirt, grass roots, can be used for high-speed operation
Fertilizer applicator	Outer groove wheel type	Simple structure, better performance of fertilization, low cost
Collection box	Trapezoidal box	Low cost, simple structure, in line with <i>Houttuynia cordata</i> bevel blanking
Separator	Roller type	Simple structure, low cost, good driving performance
Seed separator	Recessed type	Simple structure, uniform seed row, low cost, easy to process
Soil covering apparatus	Scraper	Good soil covering performance and simple structure
Suppression wheel	Cylindrical suppression wheel	Suppression effect is better, not easy to slip

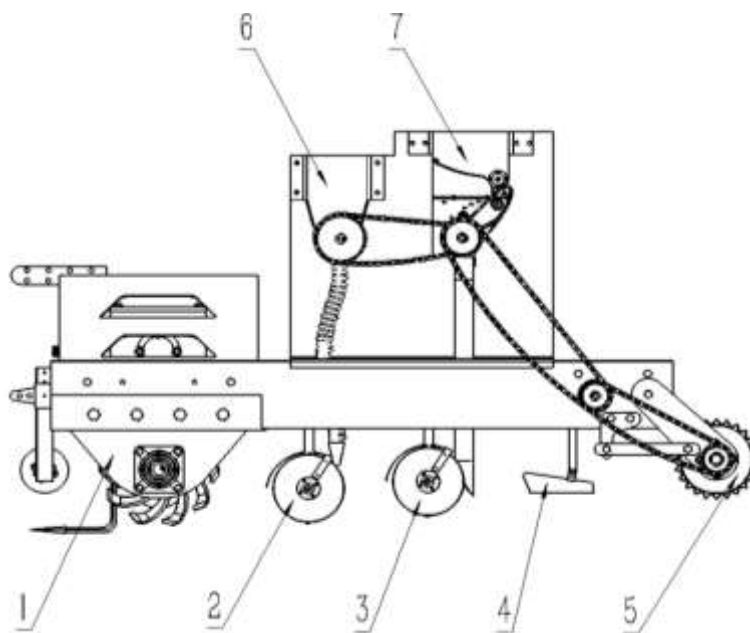
**Figure 3.** Space layout of fertilizer seeder for *Houttuynia Cordata*. 1: Rototiller; 2 and 3: sowing ditchers; 4: soil covering apparatus; 5: suppression wheel; 6: fertilizer; 7: seeding device.

The morphological matrix of the actuator was mainly used to solve the parts of the whole fertilizer seeder for *Houttuynia cordata* such as soil thinning, ditching, seeding, soil covering and

suppression (Table 2). Similarly, from the perspective of novelty and practicability, A1, B1, B5, B6, C1, C3, D1, D2, E1, E3, F1, F4, G1, H1 were generally selected for the design scheme of the

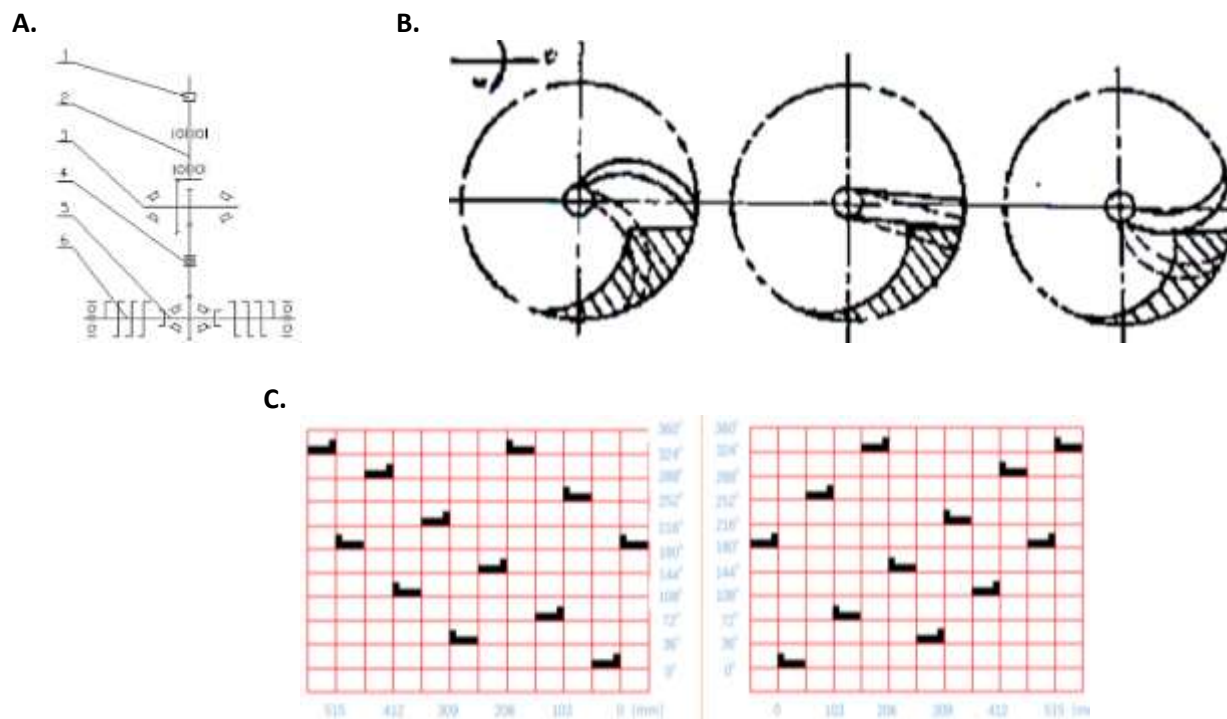

Figure 4. The schematic diagram of rototiller transmission (A), common rotary tillage blade forms (B), and phase diagram of rotary tillage tool arrangement (C). (Notes: 1: universal joint coupling; 2: input end gear shaft; 3: large bevel gear shaft; 4: transition gear shaft; 5: output end gear shaft; 6: rotary tiller knife shaft.

actuator. The number of schemes was $1 \times 3 \times 2 \times 2 \times 2 \times 2 \times 1 = 48$ (kinds).

Optimization selection of function element

After the scheme was obtained through the transmission morphology matrix and the executive mechanism morphology matrix, the function element carriers were obtained (Table 3).

The layout of function element

FSHC machine layout was shown in Figure 3. The rototiller referred to a cultivated land machine driven by external power to work with spiral blades, which was mainly composed of frame, variable speed system, rotary tillage tool shaft, blade, cover, and so on. Generally, it tilled the soil by the principle of milling, and its strong ability to cut soil and prepare the land could make the soil mix. The main function of the ditcher was to open a ditch on the flat ground when the seeder was running. The shape of the ditch should be neat to meet the needs of the sowing depth of

Houttuynia cordata. The quelling wheel was the power source of the fertilizer, which played a decisive role in the working performance of the whole machine to move the fertilizer through the chain drive belt with a certain transmission ratio.

The design and selection of functional elements (1) Rototiller

The rototiller designed in this study was a horizontal rototiller with a three-point suspension to connect to the tractor. According to the soil loosening requirements of *Houttuynia cordata* planting, the specific design parameters of the designed rototiller were shown in Table 4, while the rototiller transmission roadmap was shown in Figure 4A. The rotary tiller blade was an important working part of the rotary tiller [18], which commonly used rotary tiller knife (Figure 4B). This design of rotary tiller blade form was machete. The cutting edge of the scimitar was composed of curves including two parts of the side cutting edge and the tangent edge. When the scimitar was working, it could press the soil

and grass stem to the side of the uncultivated land, so that it was not easy to wrap the grass. According to the operation requirements and the principle of blade arrangement, the design of the arrangement of the blade followed the criteria of a classic single spiral arrangement, simple arrangement, good performance in the soil, and not easy to wrap grass. The arrangement of rotary tillage blades was shown in Figure 4C.

Table 4. Working parameters of the rototiller.

Rototiller	Parameter
supporting power	25.1 Kw
knife roll speed	290 r/min
operation width	1500 mm
working depth	150 mm

(2) Ditcher

According to the different excavation angles, the structure of ditcher can be divided into two categories including acute angle ditcher and obtuse angle ditcher [19]. A better performance ditcher should meet the following conditions that (1) the groove depth is consistent, neat, furrowed, and uniform, while the trenching depth can be adjusted within the prescribed scope and to satisfy the crop sowing depth; (2) when the ditch is opened, the soil should not be disturbed. The wet soil should not be turned to the ground, and the dry soil should not fall directly to the bottom of the ditch to make sure the sowing and fertilization applications on the wet soil; (3) the seeds in the trench are evenly distributed, so the seeds cannot fly away and should all fall to the bottom of the trench; (4) good ability to return to the soil, so that the fine wet soil to completely cover the seeds to facilitate seed germination; (5) having excellent performance and cutting soil, work safety, and should not be weeds, stubble, dirt, and with other pollution; (6) the structure is simple, the relative resistance of the work should not be too large, and the ditch should be adjusted and the maintenance is simple. The design of this study, according to the sowing requirements of *Houttuynia cordata*, selected acute angle ditcher and double disc type opener (Figure 5).

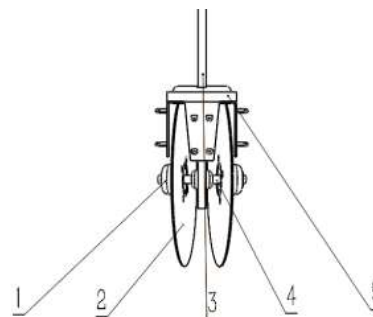

Figure 5. Structure diagram of the trench opener. (Note: 1: disk hub; 2: disk; 3: upper pull plate of the ditcher; 4: shaft of the ditcher; 5: ditcher.)

(3) Fertilizer applicator

The fertilizer applicator on planting machinery and middle-ploughing topdressing machinery is generally used for dry discharge and application of granular and powdery fertilizer, granular compound fertilizer, and home-made granular fertilizer, etc. The structure of current used fertilizer includes roughly outside groove wheel, star wheel, rotary disc type, vibration, centrifugal, jewels, and so on. The requests for a fertilizing device include (1) the total amount of fertilizer applied should be within the range of 75-450 kg/hm² and can be adjustable to meet the requirements of agronomy; (2) having good versatility and can arrange various fertilizers; (3) having low resistance to fertilizer discharge work, safe and reliable operation, simple use, easy removal of residual fertilizer in the box; (4) the parts should be resistant to corrosion and wearing. This study adopted outside groove wheel fertilization and the final design of fertilization applicator structure was shown in Figure 6.

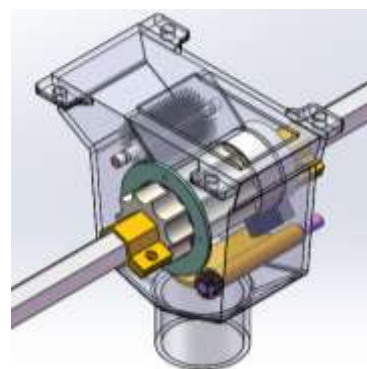

Figure 6. Fertilization applicator structure.

(4) Seed separator

In recent years, when sowing *Houttuynia cordata*, it was found that the germination rate was reduced when sowing with long stem segment, which was due to the large number of old roots and the large seed quantity. Therefore, sowing with short stem was popularized at first in this study. The detailed seeding process parameters were shown in Table 5. According to the seed shape of *Houttuynia cordata* and the requirements of sowing agronomy, a shunt type intermittent seed conveying device for flexible stripe seeds was designed in this study. A three-stage evacuation device was set up, which could evacuate a pile of *Houttuynia cordata* into a continuous *Houttuynia cordata* (Figure 7).

Table 5. Sowing process parameters of *Houttuynia cordata*.

Planting agronomy	Parameters
Planting length (mm)	40-50
Diameter(mm)	5-10
Row (rows)	6
Plant spacing (mm)	50-80
Furrow distance (mm)	300-400
Seed groove depth (mm)	80-150

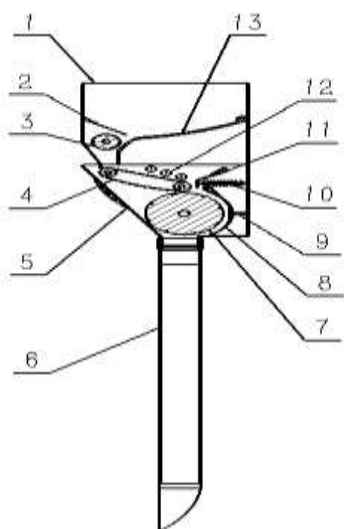
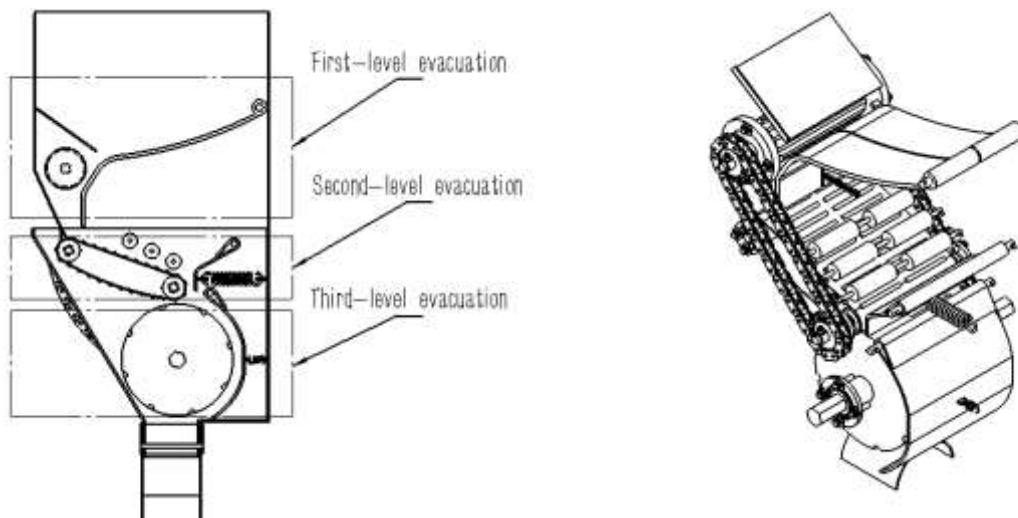

Figure 7. Schematic diagram of the seed row apparatus. (Note: 1: seed disperser upper box; 2: first level evacuation short baffle; 3: seed evacuation roller; 4: seed conveying belt; 5: seed disperser lower box; 6: seed disperser tube; 7: seed disperser intermittent groove wheel; 8: three level evacuation baffle; 9: three level evacuation spring; 10: two level evacuation spring; 11: two level evacuation baffle; 12: seed disperser baffle; 13: level 1 evacuation short baffle.)

The specific evacuation devices and evacuation principles were shown in Figure 8A. The first-level evacuation would be cleared up when *Houttuynia cordata* was orderly piled into the box body. At this time, the *Houttuynia cordata* seeding baffle could constrain the seeds through the seeding short baffle, and slowly entered the seeding roller, and then, passed through the spinner stacked on the top, making it sowing to the first level (Figure 8B). In the second-level evacuation, *Houttuynia cordata* would fall into the seed transport belt driven by the seed evacuation roller. The seed transport belt was arranged with a semicircle column bar. When *Houttuynia cordata* fell into the seed transport belt, part of *Houttuynia cordata* would fall into the gap between the bars. Driven by the seed transport belt, *Houttuynia cordata* would be transported in an orderly way. The seeds were linearly inclined arranged with the seed transport belt. In the process of transportation, because of the similarities and differences in height, the excess seeds would be separated. Then, the *Houttuynia cordata* was evacuated for the second time (Figure 8C). The three-level evacuation was basically carried out in the way of continuous and uniform transmission of intermittent pulleys. Since the intermittent groove having a homogeneous equidistant wheel set, during the rotation of the intermittent groove sowing wheel, when the *Houttuynia cordata* just fitted into the notch, it would fall into the groove where the intermittent groove sowing wheel rotated. The *Houttuynia cordata* that did not fit the right notch would be evacuated, waiting for the arrival of the next notch, thus, completing the third level evacuation (Figure 8D). The *Houttuynia cordata* that passed the evacuation of those three levels would already have the conditions for sowing. However, the current *Houttuynia cordata* falling direction was perpendicular to the direction of the trench, while the requirement for *Houttuynia cordata* planting was horizontal and should lie flat in the trench. Therefore, a curved plate was designed above the seed tube in this study. When *Houttuynia cordata* fell through the sowing intermittent groove wheel, it would just collide

A.



B.

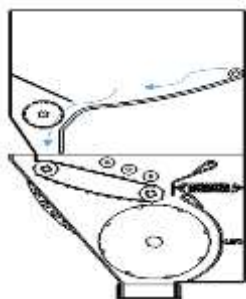

C.

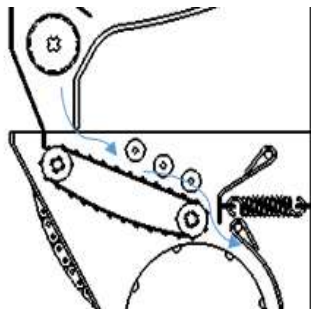

D.

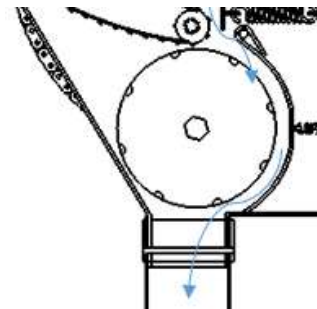

Figure 8. Evacuation device (A), the first-level evacuation (B), the second-level evacuation (C), and the third-level evacuation (D).

with the concave arc plate. So that, *Houttuynia cordata* would tilt to the side of the arc plate. In the process of falling, due to the action of gravity, *Houttuynia cordata* would fall into the ditch in a vertical way. With the advance of the machine, *Houttuynia cordata* laid flat in the ditch, so far, the completion of sowing.

Results and discussions

Check the key parts of the fertilizer applicator

According to the principle of fertilization, the fertilization amount per turn of the fertilizer applicator was determined. The row of fertilizer discharge (q_1) was calculated by using the following equation.

$$q_1 = \pi d L \gamma \left(\frac{a_0 f_q}{t} + \lambda \right) \left(\frac{g}{r} \right) \tag{1}$$

where d was the outer groove wheel diameter (cm); L was the effective working length of the groove wheel (cm); γ was the fertilizer density (g/cm^3); a_0 was the coefficient of fertilizer filling in tank; f_q was the cross-sectional area of a single groove (cm^2); T was the pitch of groove wheel (cm); t was the calculated result of $\pi d/z$, where z was the number of slots; λ was the driving layer characteristic coefficient; and r was the groove wheel radius (cm). F_q could be obtained from the geometric shape of the groove wheel with the calculation formula of the section of the circular groove below.

$$F_q = f_1 + f_2 = \frac{d^2}{8(\alpha - \text{Sin}\alpha)} + \frac{r^2}{2} \tag{2}$$

$$\varphi = \frac{2 \arcsin b}{d} \tag{3}$$

$$\varphi = \frac{2 \arcsin b}{2r} \tag{4}$$

$$b = \sqrt{\frac{d^2}{2} + 2r^2 + \frac{d^2 r^2}{2R^2} - R^2 - \frac{d^4}{16R^2} - \frac{r^4}{R^2}} \tag{5}$$

According to the international agricultural technical standards, the fertilizer discharge quantity q_2 was calculated as follows:

$$q_2 = \frac{\pi D b Q (1 + \delta)}{10i (g/r)} \tag{6}$$

where D was the diameter of suppression wheel (m); R was the radius of suppression wheel (m); Q was the agricultural technical conditions sowing amount (kg/hm²); b was the row spacing (m); i was the transmission ratio and equal to slotted wheel speed divided by driving wheel speed, while driving wheel was usually suppression wheel; δ was the slip coefficient of earth wheel. In order to ensure that the seed quantity of the outer groove wheel could meet the technical requirements of agriculture, q_1 must be equal to q_2 . Therefore, the basic formula of the outer groove wheel fertilizer was determined as follows.

$$\pi d L \gamma \left(\frac{a_0 f_q}{t} + \lambda \right) = \frac{\pi D b Q (1 + \delta)}{10i_1} \tag{7}$$

$$q_2 = \frac{\pi D b Q (1 + \delta)}{10i (g/r)} \tag{8}$$

The resulting values for each parameter in the above formula were listed in Table 6. According to the data in table 6, the following calculations were performed.

Table 6. The parameters of the formula.

Parameter value		
d=40.2 mm	L=42 mm	$f_q=0.32$
$a_0=0.9$	$\gamma=1.2 \text{ g/cm}^3$	$t=1.26$
$\lambda=0.4$	$Q=375 \text{ kg/hm}^2$	$\delta=0.1$

$$q_1 = 40.04 \frac{g}{r} \tag{9}$$

$$q_2 = \frac{155.5}{10i_1} \tag{10}$$

Because $q_1 = q_2$, therefore, $i_1 = 0.39$.

The rationality of the groove wheel speed was then verified as below.

$$v_0 = 0.54 \text{ (m/s)} \tag{11}$$

$$\omega_0 = \frac{v_0}{r_0} = \frac{0.54}{0.2} = 2.7 \text{ (rad/s)} \tag{12}$$

$$i_1 = \frac{\omega_1}{\omega_0} = 0.39 \tag{13}$$

$$\omega_1 = i_1 \times \omega_0 = 2\pi n_1 = 1.44 \tag{14}$$

$$n_1 = \frac{\omega_1}{2\pi} = 14 \text{ (r/min)} \tag{15}$$

Generally, the speed of the groove wheel was more reasonable at 9 - 60 r/min. The result of this study was 14 r/min, which was in the range of reasonable speed.

Computational checking of the key components of seed separator

For FSHC, the key parameters affecting the seeding mainly include the rotation speed of seed seeder and the slot interval of seed seeder intermittent groove wheel. In the design of this study, according to the planting length, seeding diameter, seeding ditch distance, and other

sowing agronomic parameters, the appropriate slot gap was selected according to the input speed calculation of seeding machine speed and other related parameters.

If the speed of the seed arranger was set as

$$v = r\omega \quad (16)$$

$$\omega = \frac{2\pi}{T} \quad (17)$$

$$T = \frac{2\pi r}{v} = \frac{0.1\pi}{v} \quad (18)$$

and the time required for the seeding intermittent groove wheel to rotate 24° (t) was as

$$t = \frac{24}{360} \times \frac{0.15\pi}{v_2} = \frac{\pi}{100v_2} \quad (19)$$

according to sow agronomic requirements, when the row of intermittent sheave rotating 24° , wheel walking itinerary should be 8 cm, then,

$$v_1 \times \frac{\pi}{100v_2} = 0.08 \quad (20)$$

$$v_2 = 0.39v_0 = 0.21(m/s) \quad (21)$$

$$\omega_2 = \frac{v_2}{r_2} = 2.8(\text{rad/s}) \quad (22)$$

$$n_2 = \frac{\omega_2}{2\pi} = 27(\text{r/min}) \quad (23)$$

$$i_2 = \frac{\omega_0}{\omega_2} = 1.3 \quad (24)$$

In the above formula, v_0 was the speed of the wheel; v_2 was the seeding velocity of intermittent groove wheel; ω_0 was the angular acceleration of the suppression wheel; r_2 was the radius of the batch groove wheel; n_2 was the

angular velocity of the intermittent groove wheel; ω_2 was the angular acceleration of intermittent groove wheel; i_2 was the transmission ratio between the suppression wheel and the row type intermittent groove wheel.

In summary, through the calculation verification of the key components of the seed platter, the results confirmed that the designed instrument met the agronomic requirements of *Houttuynia cordata* seeding.

Conclusions

FSHC had been designed with a multi-level scattering seeding device as the core, which greatly improved the efficiency of *Houttuynia cordata* planting and reduced planting costs. The black box method was used to analyze and determine the various functional units of the entire system, and a reasonable layout had been designed to achieve the structure of each functional element, resulting in the final design of the entire machine structure. The key parts of FSHC were calculated and selected. The structure of each functional element was designed accordingly. Through the multistage evacuation function of seeding apparatus, the hierarchical evacuation of *Houttuynia cordata* could be realized. Through the step-by-step process, a bunch of *Houttuynia cordata* was eventually dispersed to meet the conditions of sowing agriculture. After the evacuation, the *Houttuynia cordata* fell into the concave arc plate, entered the seeding tube in a vertical state, and fell into the seeding ditch along with the progress of the machine to complete the sowing. The working performance of the whole machine was improved by considering all aspects of agronomic requirements, and the functional feasibility of the key parts was verified by numerical calculations.

Acknowledgements

This research was supported by Sichuan province Science and Technology Key Project (2021JDKP0075), China and Sichuan province Science and Technology Department Key Research and Development Project (2022YFG0347), China.

References

1. Sun JX. 2022. Analysis of rural revitalization by using agricultural mechanization to develop modern agriculture. *Mod Agric Mach.* (2):21-22.
2. Zheng J, Liao YT, Liao QX, Sun M. 2022. Research situation analysis and trend prospect of seed scheduling technology of planter. *Trans Chinese Soc Agric Eng.* 38(24):1-13.
3. Li G, Gu RR, WuYB. 2023. Research status of harvesting device of rhizome crops. *China Southern Agric Mach.* 54(01):53-55, 62.
4. Wang LP. 2020. Cultivation technology of *Houttuynia cordata* in plastic greenhouse in Yangtze River basin. *J Changjiang Veg.* 15-19.
5. Min H, Mao XL, Zhan GQ. 2018. Current situation and suggestions of planting industry of *Houttuynia Cordata* in Zhejue Town, Weining County. *Agric Tech Serv.* 35(4):103-104.
6. Yang F, Xie QL, Zhang GF, Xu DJ. 2016. Standardized artificial cultivation technology of folium folium. *China Fruit Veg.* 36(12):73-75.
7. Li J. 2021. Key points of high-yield cultivation technology of *Houttuynia Cordata*. *Agric Eng Tech.* 41(2):73-75.
8. Shang SM, Zhang XJ, Ma TY, Zhang H, Yu FC, Qi HY, *et al.* 2021. Inhibitory effect of *Houttuynia cordata* extract on proliferation of colon cancer cell HCT116. *J Mudanjiang Normal University (Natural Science Edition).* 2021(4):36-39.
9. Qi S, Cha LY, Huang DF, Luo W, Chen KL, Yin DM. 2022. Innovation and development of planting technology of *Houttuynia Cordata*. *Northern Hortic.* (17):121-128.
10. Wang Q, Wang HL, Li DD, Du Zhong Y, Gong JF, Li YX. 2022. Standardized cultivation and management techniques for edible and medicinal *Houttuynia cordata* in Guizhou region. *Contemp Hortic.* 45(11):52-55.
11. Wang JH, Qin SY, Fu J, Peng SM. 2023. Overview of application research on *Houttuynia cordata*. *China Food Safe Mag.* 2023(01):183-185.
12. Jiang CY, Liu WL, Liu F, Xiao J, Hu H, Wang XY, *et al.* 2018. A kind of root crop planting equipment. *Agric Mach Using Maint.* (9):1-5.
13. Wu FH, Wang F, Qi CD, Gao SH, Wu D, Zhu L, *et al.* 2022. Whole-process mechanized production technology of *Houttuynia Cordata*. *J Changjiang Veg.* 2022(1):6-8.
14. Ge XG, Xiao TH. 2011. Analysis of black box theory. *China Educ Tech Equip.* 2011(18):93-94.
15. Ge RG. 2021. Using the black box model to promote chemistry learning. *Chem Teach Learn.* 2021(19):21-23.
16. Liu XP, Chen XP, Lu Q, Tang YM. 2012. Research on the visualization method of functional tree similarity reasoning process. *J Graphics.* 33(04):1-6.
17. Luo DJ. 2019. Design of mechanical system of rotary filling machine by morphological matrix method. *Intern Combust Engine Parts.* 2019(18):238-239.
18. Gu Y, Jiang XB, Dun GQ. 2022. Research status and development trends of rotary tillers. *China Southern Agric Mach.* 53(23):44-46.
19. Zhao YZ, Gou JB, Wang YF, Dong SK, Zhao SH. 2022. Design and Experiment of an Involute Side Deep Fertilization Ditcher for No-tillage Planters. *J Northeast Agric University.* 53(12):91-100.